

Mini-Regenerative Air Dryer

MINI-REGENERATIVE AIR DRYER

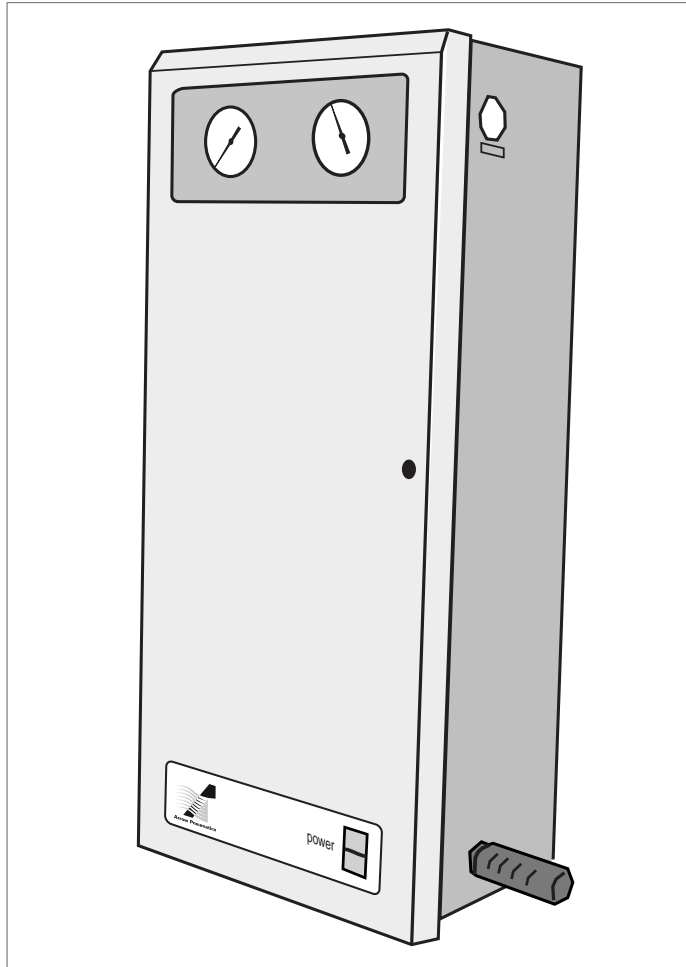

MODELS RH105 THROUGH RH125

SPECIFICATIONS

MODEL	DRYING CAPACITY SCFM	PURGE SCFM	IN/OUT CONN.
RH105	5	.71	1/2" NPT
RH110	10	1.41	1/2" NPT
RH115	15	2.12	1/2" NPT
RH120	20	2.82	1/2" NPT
RH125	25	3.53	1/2" NPT

- CAPACITIES ARE BASED ON 100°F INLET TEMPERATURES, 100°F AMBIENT TEMPERATURES AND 100 PSIG INLET PRESSURE.
- MAXIMUM WORKING PRESSURE: 150 PSIG
- MINIMUM WORKING PRESSURE: 75 PSIG
- MAXIMUM INLET TEMPERATURE: 120°F
- MINIMUM INLET TEMPERATURE: 32°F
- STANDARD -40°F PRESSURE DEW POINT
- OPTIONAL -100° PRESSURE DEW POINT
- STANDARD CYCLE TIME: 5 MINUTES
- OPTIONAL CYCLE TIME: 2 MINUTES WITH -100°F PRESSURE DEW POINT
- ENCLOSURE: NEMA 1
- STANDARD VOLTAGE: 120V, 1 PHASE, 60 HZ
- OPTIONAL VOLTAGE: 220V, 1 PHASE, 60HZ
- AMPS: 1.0
- STANDARD POWER PLUG: 6 FT. HEAVY-DUTY 3 PRONG GROUNDED

DIMENSIONS

MODEL	HEIGHT	WIDTH	DEPTH	WEIGHT
RH105	22"	10"	5"	50 LBS
RH110	22"	10"	5"	60 LBS
RH115	30"	12"	8"	70 LBS
RH120	30"	12"	8"	90 LBS
RH125	30"	12"	8"	90 LBS

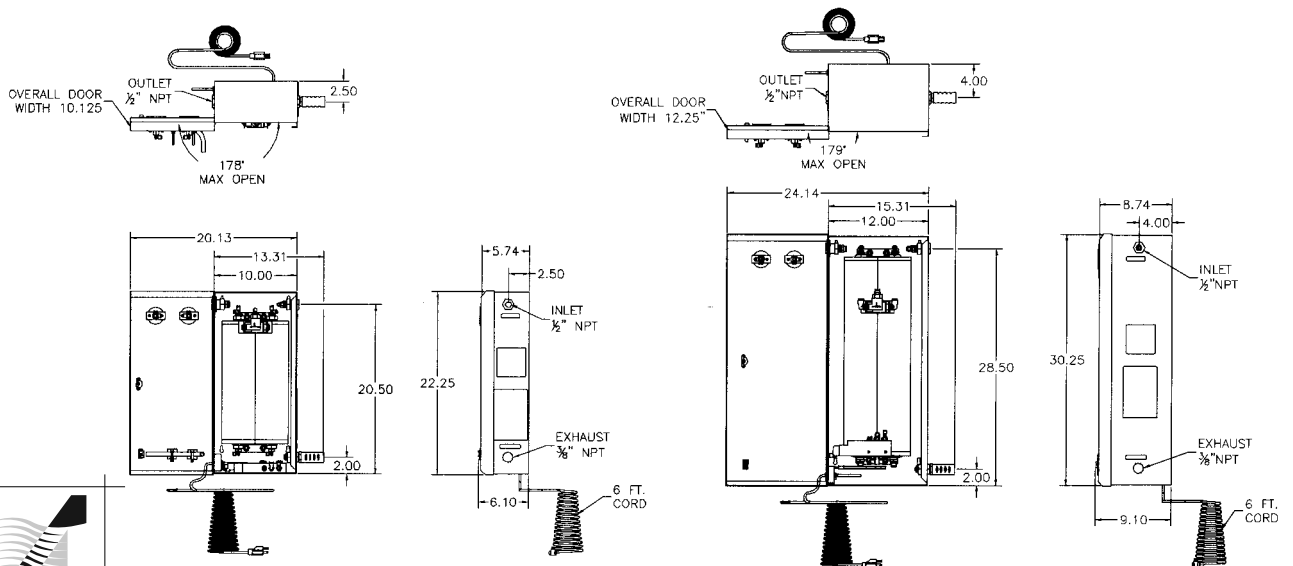

READ CAREFULLY BEFORE ATTEMPTING TO INSTALL, OPERATE OR MAINTAIN YOUR DRYER. PROTECT YOURSELF AND OTHERS BY OBSERVING ALL SAFETY INFORMATION. FAILURE TO DO SO COULD RESULT IN PERSONAL INJURY AND/OR PROPERTY DAMAGE. KEEP OWNER'S MANUAL FOR FUTURE REFERENCE.

UNPACKING

ARROW REGENERATIVE AIR DRYERS ARE SHIPPED AS COMPLETELY ASSEMBLED PACKAGES FILLED WITH DESICCANT READY TO INSTALL.

VISUALLY CHECK THE DRYER FOR DAMAGE THAT MAY HAVE OCCURRED IN TRANSIT. IF THERE IS EVIDENCE OF DAMAGE, IMMEDIATELY ENTER A CLAIM WITH THE CARRIER, AND NOTIFY YOUR ARROW REPRESENTATIVE.

APPLICATION CHECK AND ANALYSIS

TO ACHIEVE THE BEST DRYER PERFORMANCE, YOU SHOULD CAREFULLY CHECK THAT THE DESIGN AND INSTALLATION REQUIREMENTS OUTLINED BELOW ARE SATISFIED.

- ① Operating pressure of your Arrow Dryer can range from 75 minimum to 150 maximum PSIG. Check dryer label to verify maximum service pressure. Air available for your air usage will vary with operating pressure.
- ② The dryer should not be installed where compressed air and/or ambient temperature exceeds 120°F or drops below +32°F. Locate dryer to avoid extremes of heat and cold from other conditions. Best results occur when dryer is located as close to point of use as practical. Avoid locating dryer outside or where it is exposed to the elements.
- ③ Dryers are sized according to airflow not pipe size. Dryer requires 10% to 15% of inlet air-flow (SCFM) for regeneration. The difference between the inlet and outlet flow is the amount of purge air required. This air is purged to atmosphere and is not available for use downstream. Make certain air supply to dryer meets your air demand plus purge air requirements.

MOUNTING SPECIFICATIONS AND DRYER LOCATION

Generally, locate your dryer downstream from the air receiver. The only exception would be on applications with a fluctuating demand. Then the dryer should be located upstream of the receiver to avoid air surges through the dryer's desiccant beds.

Provide adequate space around the dryer for servicing.

Four mounting holes are provided in the rear of the cabinet, use the provided bolt hole template to secure dryer to the wall. Arrow recommends using (4) #14 round head wood screws, #14 round of pan head machine screws, #14 pan head self tapping or sheet metal screws or 1/4" round or pan head machine screws for mounting. Mount dryer vertically in an upright position at desired location.

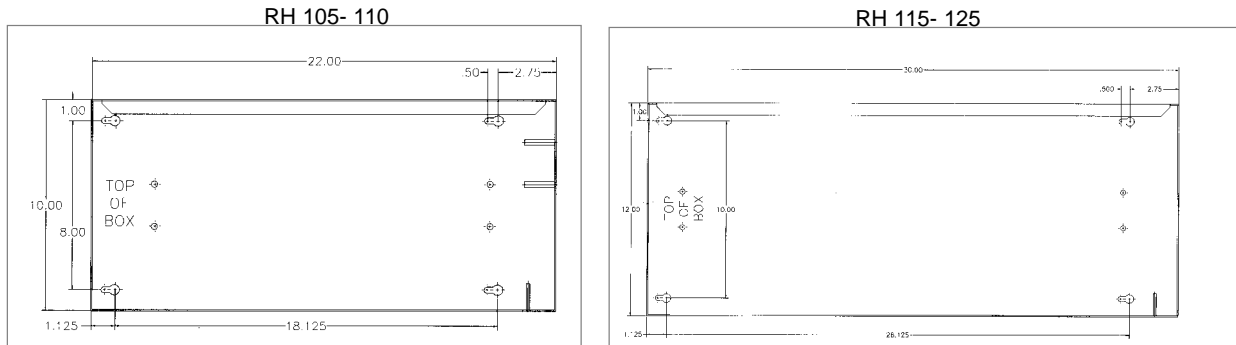

PIPING ARRANGEMENT & FILTER INSTALLATION

- ① Remove all pipe plugs from the dryer. Take care to insure that pipe dope, pipe tape, scale or metal chips are not trapped before the inlet port.

Note: Pre & After Filters Must Be Used On All Units

- ② Install **Pre-Filters** to "Inlet Air" connection on side of cabinet.
 - Wet air inlet should be connected to **pre-filter** connection on the side of cabinet.
 - In situations where air supply is required 24 hours a day (it is undesirable to interrupt the airflow), a three valve bypass system is recommended to bypass the dryer and filters. Use the fewest elbows and taper connections necessary to keep pressure drop at a minimum.
 - Compressed air entering the dryer must be cooled to at least 120°F.
 - Pre-filters, located before the dryer, protect desiccant beds from contamination by oil, entrained water, pipe scale, etc., thereby extending dryer desiccant life. Locate pre-filters as close to the dryer as possible.
 - It is recommended that a mechanical separator be installed immediately preceding the pre-filter to remove the bulk liquid oil and entrained water.
- ③ Install **After Filter** to "Outlet Air" connection on side of cabinet.
 - Dry air outlet should be connected to **after-filter** connection on the side of cabinet.
 - After filters, located after the dryer, help eliminate the possibility of desiccant dusting and carry over into the air system.
- ④ Install Purge Muffler (shipped separately inside of cabinet) to the connection marked "Purge Air" on the side of the cabinet.

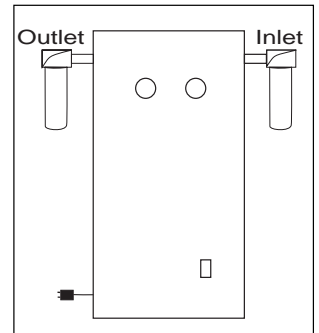

- If Purge Muffler is piped away from dryer - The exhaust muffler must be periodically checked for any restrictive debris. At high pressure, a clogged muffler could result in high back pressure and could result in increased dew point, mechanical failure or personal injury.

ELECTRICAL CONNECTION

- ① Check to see that the power supply to the dryer is the same as the power requirements indicated on the identification label.
- ② Confirm that the lighted ON/Off switch is in the OFF position.
- ③ Install the power cord plug into receptacle.

WIRING DIAGRAM

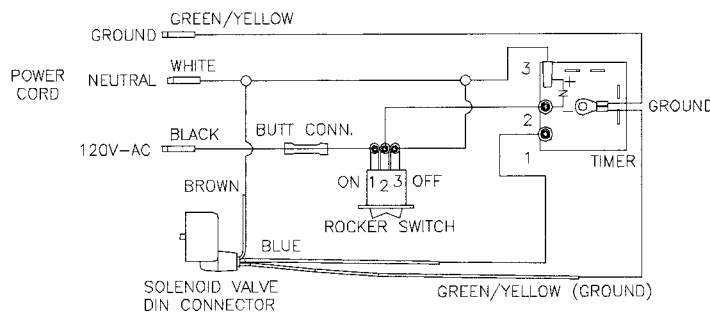

START-UP OPERATIONS

AFTER ALL PIPING AND ELECTRICAL CONNECTIONS ARE MADE, PROCEED AS FOLLOWS:

- ① **SLOWLY PRESSURIZE THE DRYER!**
- ② When the dryer reaches full operating pressure, check the system for air leaks. Soap test all joints and fittings. To maintain desired dew point, any leaks detected must be fixed, especially those on the outlet side of the dryer.
- ③ Energize electrical circuit by simply pressing the on/off switch to the "ON" position. The switch indicator light will be illuminated when the dryer is in operation.
- ④ When the electrical circuit has been energized, the control circuit board will start to operate and automatically initiate dryer operation. The timer is factory set, so that no field adjustment is necessary.

OPERATION OF THE DRYER SHOULD ONLY TAKE PLACE WHEN USING COMPRESSED AIR. WHEN THE COMPRESSOR IS SHUT DOWN, THE DRYER SHOULD ALSO BE SHUT OFF. FAILURE TO DO SO COULD LEAD TO PREMATURE FAILURE.

DRYER OPERATION

The inlet wet compressed air enters the dryer and is directed into tower "A" through the switching valve. The wet air passes through the desiccant bed while the activated alumina strips moisture leaving dry service air. A portion of this extremely dry air is passed through the fixed orifice shuttle check valve and flows downward through tower "B" drying out the saturated desiccant and exhausting out of the purge muffler.

This "REGENERATING OPERATION" is actually two cycles: one for drying service air, and one for drying desiccant. After approximately five minutes, the switching valve redirects flow, repeating the cycle. These cycles are reduced to two minute cycles if the -100°F dew point is selected.

Required purge air is generally 15% of rated flow.

All Arrow Pneumatic Mini-Regen Dryers have less than a 2 PSIG Maximum Pressure Drop at standard conditions.

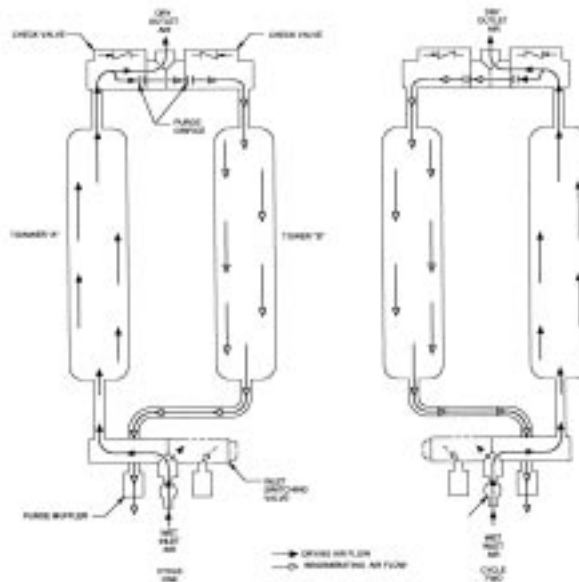

MAINTENANCE

- Your Arrow Dryer will give you years of service if the filters and drains ahead of the dryer are properly maintained on a manufacturers recommended schedule.
- Arrow also suggest replacing the desiccant in the vessels approximately every three (3) years.
- Operating conditions will have to be taken into consideration and the schedule adjusted accordingly.

NOTE: BEFORE MAINTENANCE OF DRYER ALWAYS SHUT DRYER OFF, DISCONNECT THE ELECTRICAL SUPPLY, AND DEPRESSURIZE THE PNEUMATIC SYSTEM TO AVOID PERSONAL INJURY

REPLACEMENT PARTS

PART DESCRIPTION	MODEL				
	RH105	RH110	RH115	RH120	RH125
REPLACEMENT DESICCANT (ACTIVATED ALUMINA)	126738	126738	126739	126740	126740
REPLACEMENT DESICCANT (-100°F DEW POINT) (MOLECULAR SIEVE)	126741	126741	126742	126743	126743
PRESSURE GAUGE	126065	126065	126065	126065	126065
MUFFLER	SQF-3	SQF-3	SQF-3	SQF-3	SQF-3
ON/OFF SWITCH	57300	57300	57300	57300	57300
5 MINUTE TIMER 120V	126707	126707	126707	126707	126707
5 MINUTE TIMER 220V	126750	126750	126750	126750	126750
2 MINUTE TIMER 120V (-100°F DEW POINT)	126708	126708	126708	126708	126708
2 MINUTE TIMER 220V (-100°F DEW POINT)	126751	126751	126751	126751	126751
SWITCHING VALVE	126067	126067	126067	126107	126107
SWITCHING VALVE REPAIR KIT	126067-RK	126067-RK	126067-RK	126107-RK	126107-RK
ORIFICED CHECK VALVE	126081	126082	126084	126085	126093

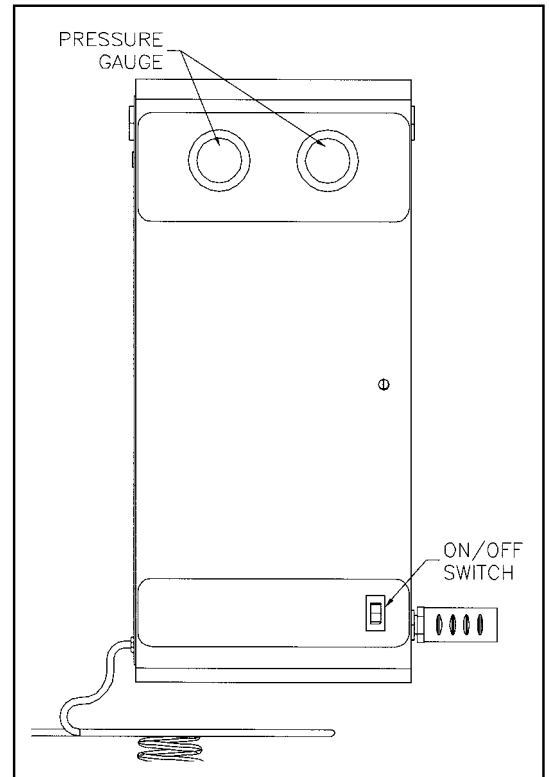
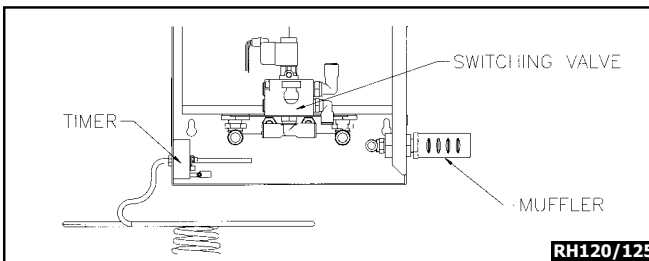
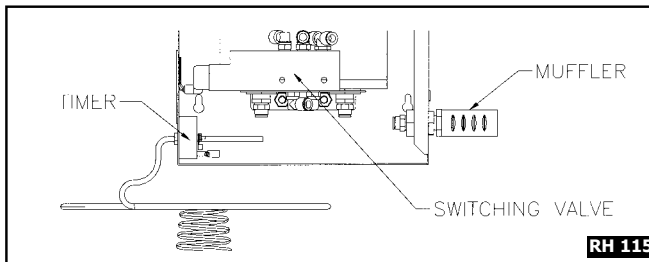
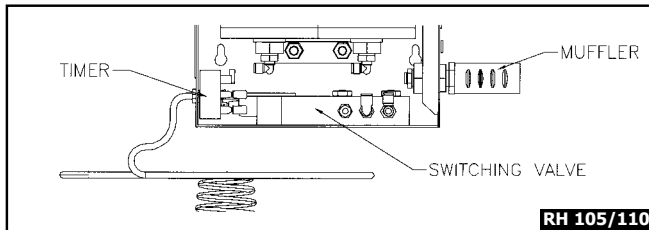

The Arrow Regenerative type compressed air dryer is warranted to be free from defects in material and workmanship, when used under conditions recommended by the manufacturer, for a period of 12 (twelve) months from date of shipment from factory to job site of original owner. Products purchased from warehouse stock are warranted for a period of 12 (twelve) months from date of shipment from that warehouse provided Arrow is furnished full name, address and date of shipment information.

This warranty is limited to parts and labor F.O.B. factory, and is subject to the same restrictions as outlined below concerning misuse, abuse or accident.

This warranty will apply to equipment installed, operated, and maintained in accordance with the procedures and recommendations as outlined in the owners manual published by Arrow Pneumatics.

During the life of this warranty, Arrow Pneumatics will repair or replace (at Arrow's option) free of charge, F.O.B. its plant, any defective part of assembly, if such defect occurred in normal service and was not due to apparent misuse, abuse, or accident.

Any warranty service performed in the field must be authorized by Arrow Pneumatics. Unauthorized service voids the warranty and resulting charge will not be paid by Arrow Pneumatics.

Arrow Pneumatics makes no other warranties or guarantees, expressed or implied. The merchantability of the components is expressly excluded. The manufacturer assumes no liability for indirect or consequential damage.

(This warranty good only in the continental boundary of the United States. For export, contact the factory)

