

# Refrigerated Air Dryers

# NEW

## 3 in 1 Dryers High Inlet Temperature

**DRY AIR TECHNOLOGY**  
by **ARROW PNEUMATICS**

## Features :

- ◆ 3 in 1 design eliminates the need for an aftercooler, separator and drain trap before the air dryer
- ◆ Stainless Steel Heat Exchanger
- ◆ Pressure Dew Point as low as 35°F
- ◆ Filter Element - 40 Micron
- ◆ Mechanical moisture separator with zero loss demand drain
- ◆ Handles Inlet Air Temperature up to 180°F
- ◆ Includes monitoring instrumentation
- ◆ Six foot electrical cord with grounded plug on Models F-3528-F3530 with 115 volts
- ◆ Refrigeration system utilize environmentally safe R-134A refrigerant
- ◆ Dew point indicator
- ◆ Two year warranty
- ◆ Five year heat exchanger warranty



**Model F-3528**

**Model F-3529  
& F-3530**

**Model F-3531  
& F-3532**

## Features NEW Cabinet Design

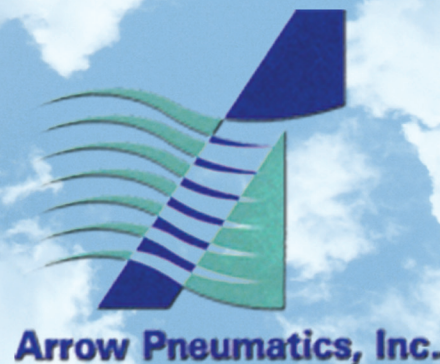

2111 West 21st Street, Broadview, Illinois 60155 Ph. 708-343-9595 Fax 708-343-1907  
Visit our website at [www.arrowrefrigdryers.com](http://www.arrowrefrigdryers.com)

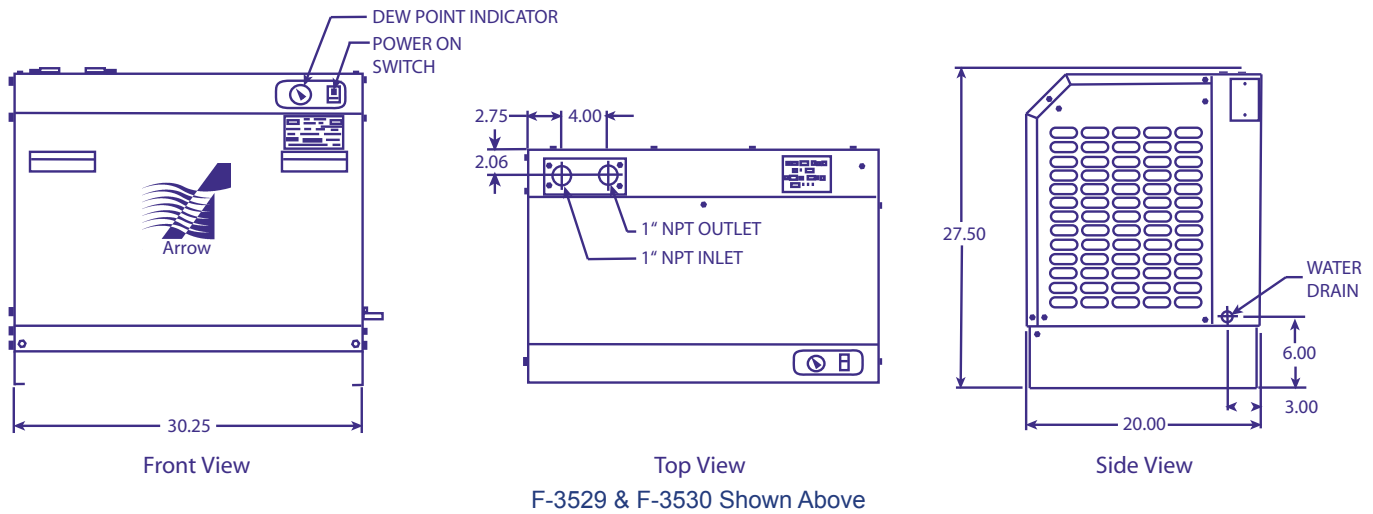

Flow Capacity CFM @ 160°F/35°F Pressure Dew Point			
Model	100 PSIG	140 PSIG	175 PSIG
F-3528	21	21.9	24
F-3529	30	36.8	40
F-3530	50	56	64
F-3531	70	81	88
F-3532	105	130	140

Flow Capacity CFM @ 140°F/35°F Pressure Dew Point			
Model	100 PSIG	140 PSIG	175 PSIG
F-3528	24	27	29
F-3529	44	49	53
F-3530	70	78	83
F-3531	85	95	102
F-3532	148	167	178

Flow Capacity CFM @ 120°F/35°F Pressure Dew Point			
Model	100 PSIG	140 PSIG	175 PSIG
F-3528	34	37	39
F-3529	50	58	64
F-3530	70	81	90
F-3531	100	115	128
F-3532	210	229	240

Specifications													
Model No.	H.P.	Air Flow CFM*	Volts	Amps RLA	LRA	Max. Fuse	Rerfrig Charge* R-134A	Dimensions (Inches)			Air Line Conn.	KW Input	Weight Lbs.
								Length	Height	Width			
F-3528	1/4	21	115/1/60	5.3	29	15	20 oz.	22	16.0	14	1" NPT	.63	84
F-3529	1/2	30	115/1/60	5.36	30	15	1.8 Lbs	30	27.5	20	1" NPT	1.14	147
F-3530	1	50	115/1/60	16.9	78	20	2.8 Lbs.	30	27.5	20	1" NPT	2.28	187
F-3531	1.25	70	230/1/60	12.4	61	15	3.8 Lbs.	34	33.0	27.5	2" NPT	3.78	275
F-3532	1.5	105	230/1/60	16.0	82	20	4.5 Lbs.	34	33.0	27.5	2" NPT	4.45	280

**STANDARD INSTRUMENTATION**  
**F-3528 thru F-3532**

On/Off Switch with Power On Light & Dew Point Indicator. Air Inlet Temperature on F-3531 & F-3532 only

NOTE: Above units are rated for 160°F saturated air inlet temperature due to the fact that there is physically no more moisture heat above this temperature. The units, however, are designed for 180°F inlet air temperature and 100°F ambient temperature. Maximum operating pressure is 250 psig

**Your Source For All  
Your Dry Air Needs**



2111 West 21st Street, Broadview, Illinois 60155 Ph. 708-343-9595 Fax 708-343-1907  
Visit our website at [www.arrowrefrigdryers.com](http://www.arrowrefrigdryers.com)

X1056  
0305  
sjf